

A.D.F.O. (N) D.F.S. (N) Member B.P.C.

Set-02(17-35)
 S.P. (G) S.P. (H) S.P. (I)
 Member Secretary Member B.P.C. Member B.P.C.
 J.D. B.P. A.P.

DINESH KUMAR SD (H.O.)

PROFESSIONAL APPROVED BUILDING PLAN

Architect (H.O.)
 Designer and Country Planning
 Hyderabad, Chandrababu Naidu
 Hyderabad, Chandrababu Naidu

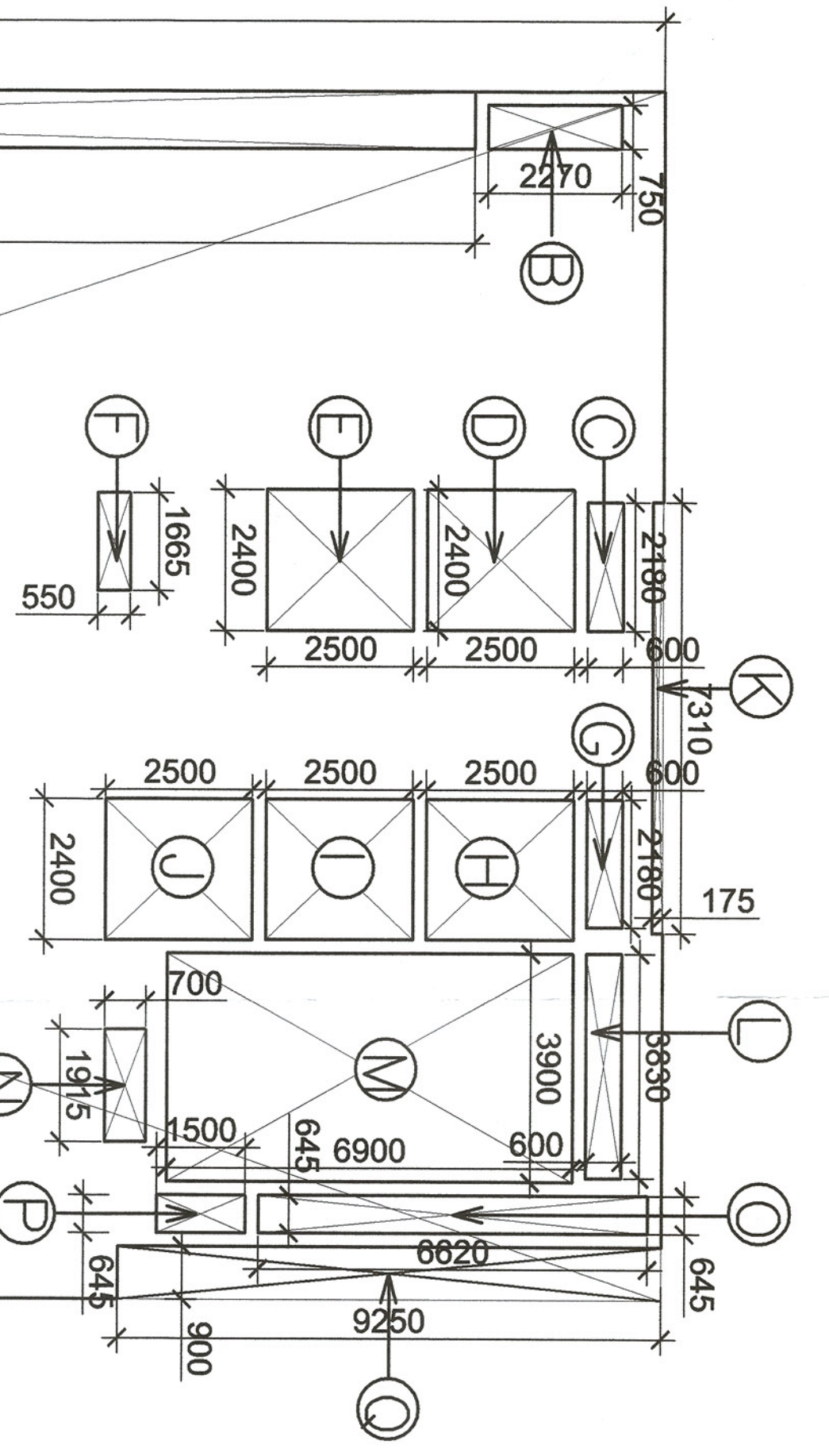
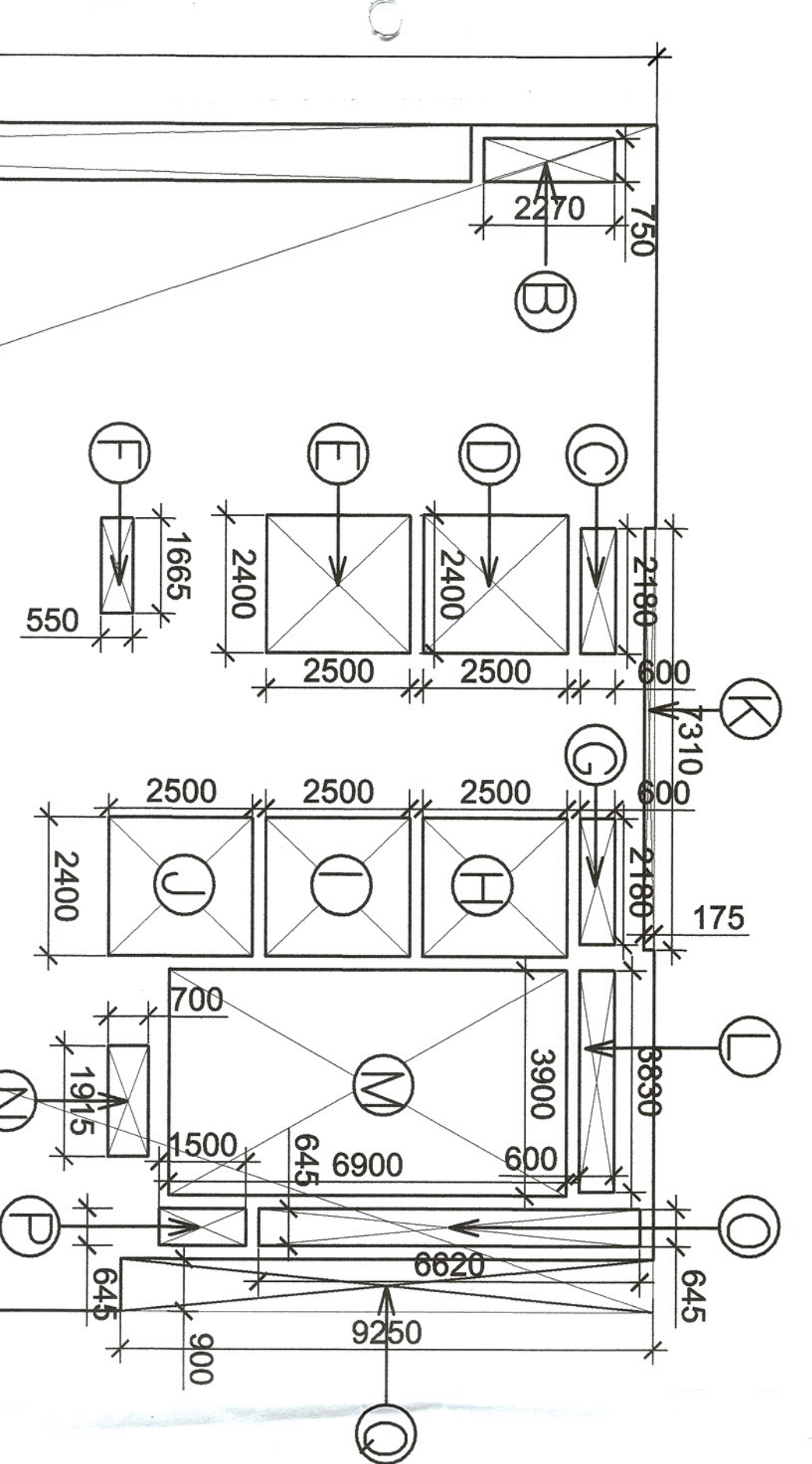

5th Floor Additions	Sq.mts
1	20560
Total Covered Area on 5th Floor	1075288

4th Floor Additions	Sq.mts
1	20560
Total Covered Area on 4th Floor	1075288

Deductions	Area	Total Deductions
A	980	34055
B	2270	750
C	2180	600
D	2400	2500
E	2400	2500
F	1665	550
G	2180	600
H	2500	2400
I	2500	2400
J	2500	2400
K	7310	175
L	3830	600
M	1915	700
N	1500	645
O	6620	645
P	1500	645
Q	9250	900
R	19575	230
S	4830	230
T	600	505
U	600	505
V	605	505
W	865	505
X	1900	3000
Y	3900	2765
Z	4870	3015
A1	1735	700
A2	1860	820
A3	2035	1400
A4	300	600
A5	5245	230
Total Deductions area	1737521	

4TH FLOOR AREA DIAGRAM

5TH FLOOR AREA DIAGRAM

REVISIONS:

- 1. ALL THE SHALL STATE, DIMENSIONS, ETC.
- 2. ALL THE DIMENSIONS SHALL BE IN METERS AND MILLIMETERS.
- 3. ALL THE DIMENSIONS SHALL BE TO FACE UNLESS SPECIFIED OTHERWISE.
- 4. ALL THE DIMENSIONS SHALL BE TO FACE UNLESS SPECIFIED OTHERWISE.
- 5. ALL THE DIMENSIONS SHALL BE TO FACE UNLESS SPECIFIED OTHERWISE.
- 6. ALL THE DIMENSIONS SHALL BE TO FACE UNLESS SPECIFIED OTHERWISE.
- 7. ALL THE DIMENSIONS SHALL BE TO FACE UNLESS SPECIFIED OTHERWISE.
- 8. ALL THE DIMENSIONS SHALL BE TO FACE UNLESS SPECIFIED OTHERWISE.
- 9. ALL THE DIMENSIONS SHALL BE TO FACE UNLESS SPECIFIED OTHERWISE.
- 10. ALL THE DIMENSIONS SHALL BE TO FACE UNLESS SPECIFIED OTHERWISE.

KEY PLAN

ORIENTATION

ACPL Design Ltd
 501, 500/1, 500/2
 Hyderabad
 www.acpldesign.com

REVISED BUILDING PLAN OF COMMERCIAL BUILDING NO. 16 OF PHASE 2A AND 2B TOWERS SECTION - 7th DISTT. - GURDWARAN MANSAR URBAN COLLABORATION WITH SPACE TOWERS PVT. LTD.

OWNER/AUTH. SIGNATURE ARCHITECT'S SIGNATURE

FOURTH & FIFTH FLOOR (AREA DIAGRAM)

SCALE :- 1:100